

# CATV & SAT-IF Optical Transmitter

## User manual

### Wall-mountable Series



# **1. Product overview**

## **1.1 Features**

1.1.1 Adopt low noise imported DFB laser.

1.1.2 Superior pre-distortion circuit design, in achieving high standards of CNR value, there are still perfect CTB and CSO performance value.

1.1.3 Intelligent fan, it began to run when the chassis temperature reaches the set 32 ~ 35 °C.

1.1.4 AGC control, so that different RF input level can still maintain a considerable output performance.

1.1.5 VFD or LED display, with laser monitoring, digital display, fault alarm, network management and other functions; once the laser operating parameters deviate from the software set the allowable range, will alert.

1.1.6 With standard RS232 interface for local network management and monitoring of computers.

1.1.7 With standard RJ45 interface support SNMP for remote monitoring.

1.1.8 High-quality switching power supply 90V ~ 265V AC

1.1.9 Single input with frequency 47~2600MHz.

## **2. Installation method**

### **2.1 Prepare before installation**

2.1.1 Check if the equipment is noticeably damaged.

2.1.2 Check all accessories are available, whether the certificate is complete, if damaged or missing parts of the situation, according to the return process.

### **2.2 Installation**

2.2.1 In the installation of multiple devices, up and down between at least 1.75 inches (about 4.5cm) of space, in order to facilitate the ventilation and heat dissipation.

2.2.2 Check that the power outlet and grounding will be used properly, grounding

resistance should be  $\leq 4 \Omega$ , improper grounding may damage the device or lead to poor signal quality.

2.2.3 Before connecting the power cord, make sure that the power switch on the rear panel is in the OFF position.

2.2.4 Connect RF signal with coaxial cable.

2.2.5 Connect the external fiber, the fiber must be cleaned before the connection, fiber optic connector can choose FC / APC or SC / APC form.

### 3. Set up and operate

#### 3.1 Diagram

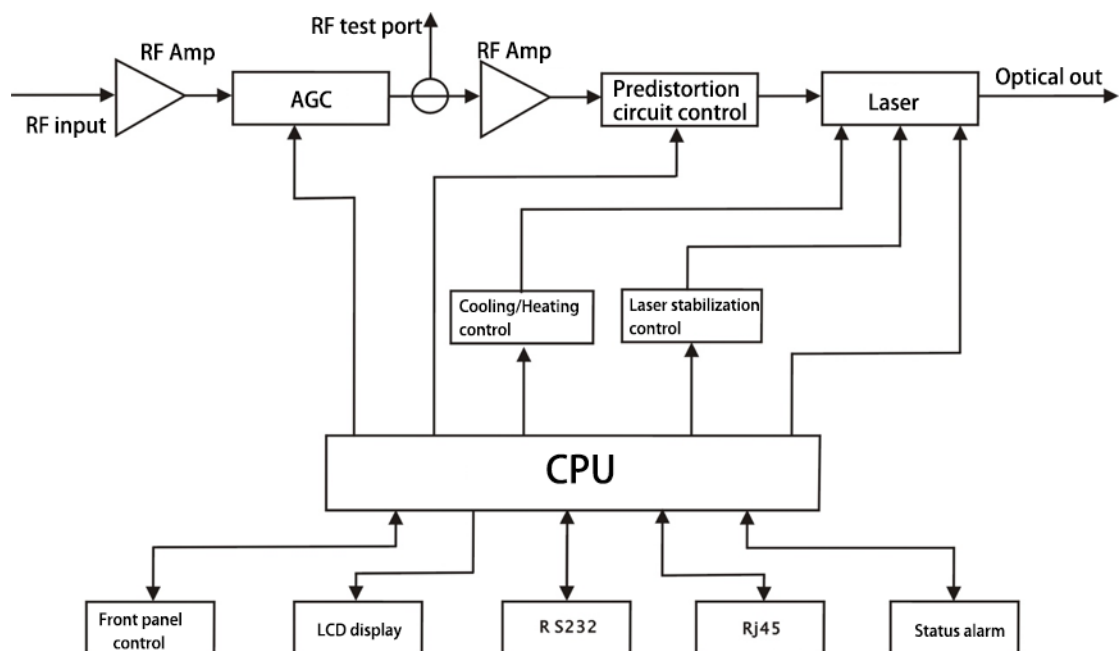

### 3.2 Technical index

Item	Parameter	
Optical output power (mW)	2~10	
Wavelength (nm)	1310, 1550 option	
Optical connector	FC/APC, SC/APC, SC/PC, LC/APC, ,LC/PC option	
Working bandwidth (MHz)	47~2600	
CNR (dB)	≥51	42CH CENELEC 80dBuV AGC OMI=3.8%
CTB (dB)	≥63	
CSO (dB)	≥58	
Input level (dBμV)	80±5	
Flatness (dB)	47~950MHz	≤±0.75
	950~2600MHz	≤±1.00
Power consumption (W)	≤30	
Power supply (V)	220VAC, -48VDC option	
Working temp (°C)	-20~85	
Size (mm)	350×200×45	
Weight (Kg)	3.0	

### 3.3 Up panel



#### 3.3.1 VFD/LED display

Display satellite optical transmitter parameter, such as model number and work situation.

#### 3.3.2 Status indicator

The green light indicates normal and the red light is abnormal

#### 3.3.2 Laser indicator

The green light indicates normal and the red light is abnormal

#### 3.3.3 RF indicator

The green light indicates normal, and the red light indicates that the RF input is too

low or too high

### 3.3.3.1 Power indicator

The green light indicates two ways switch power supply working, the yellow light indicates one-way power supply working, the red light indicates abnormal.

## 3.4 Side panel



### 3.4.1 Fan

Intelligent fan, it began to run when the chassis temperature reaches the set 32~35 °C.

### 3.4.2 RF IN

RF input

### 3.4.3 Power supply switch

ON: Open up means 12VDC, open down means 18VDC, in middle means turn off.

### 3.4.4 RF test

Input -20dB

### 3.4.5 OPT OUT

Optical signal output.

### 3.4.6 RS232

For local computer network management.

### 3.4.7 RJ45

Compliant with SNMP standard interface.

### 3.4.8 Power outlet

220V single

### 3.5 Operating procedures

The following menu shows all using the down arrow button; the up arrow button can be reversed.

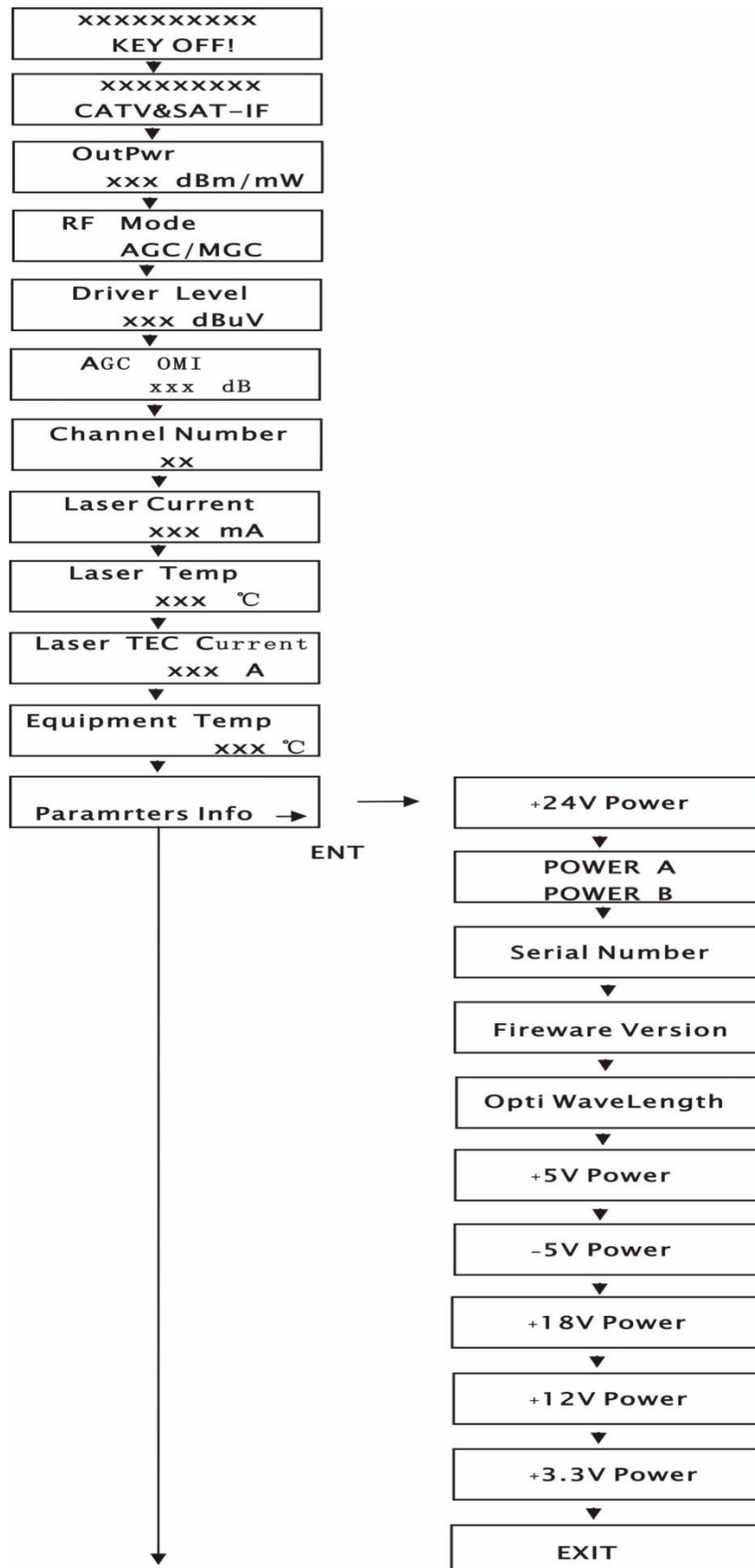

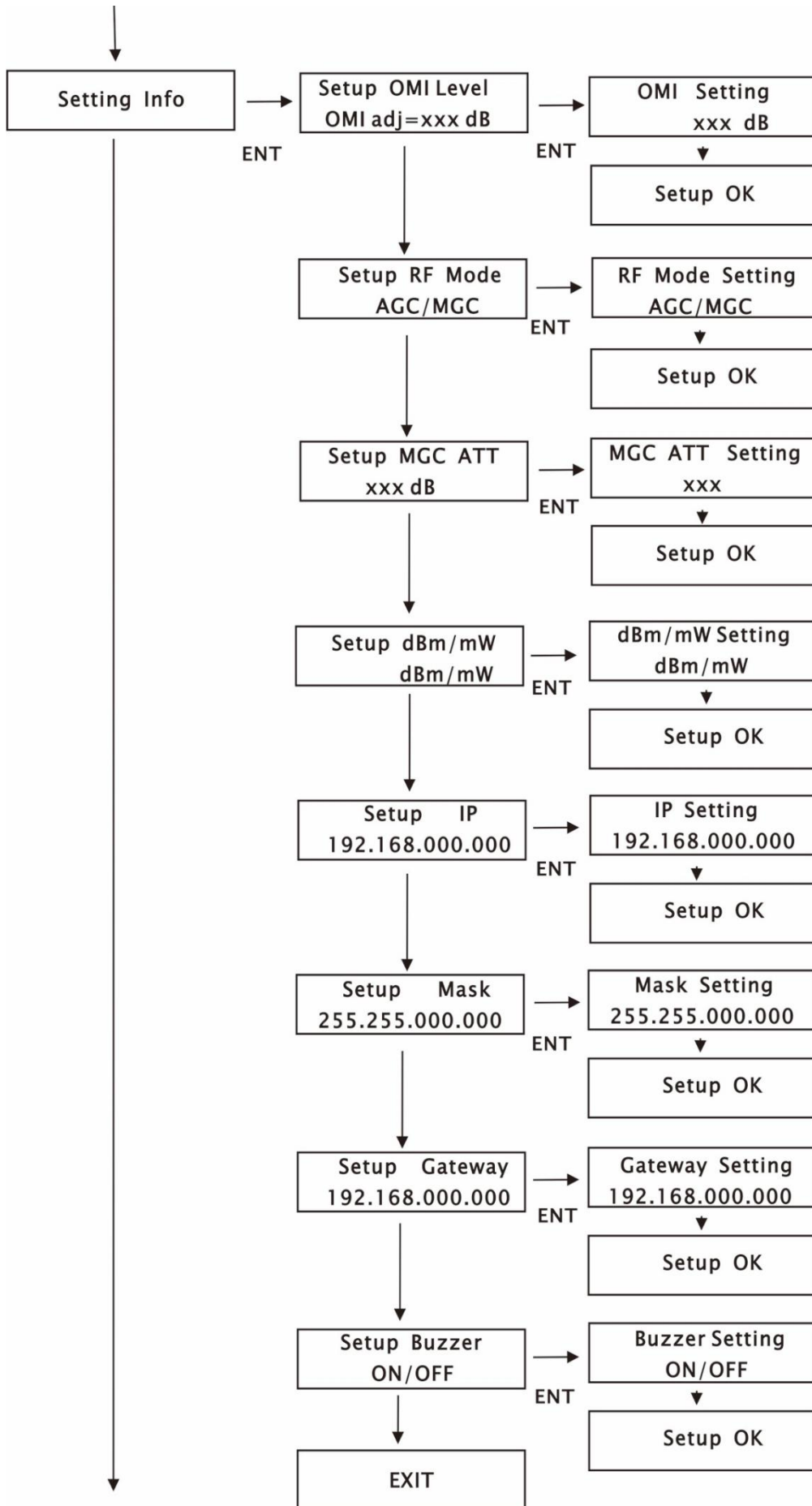

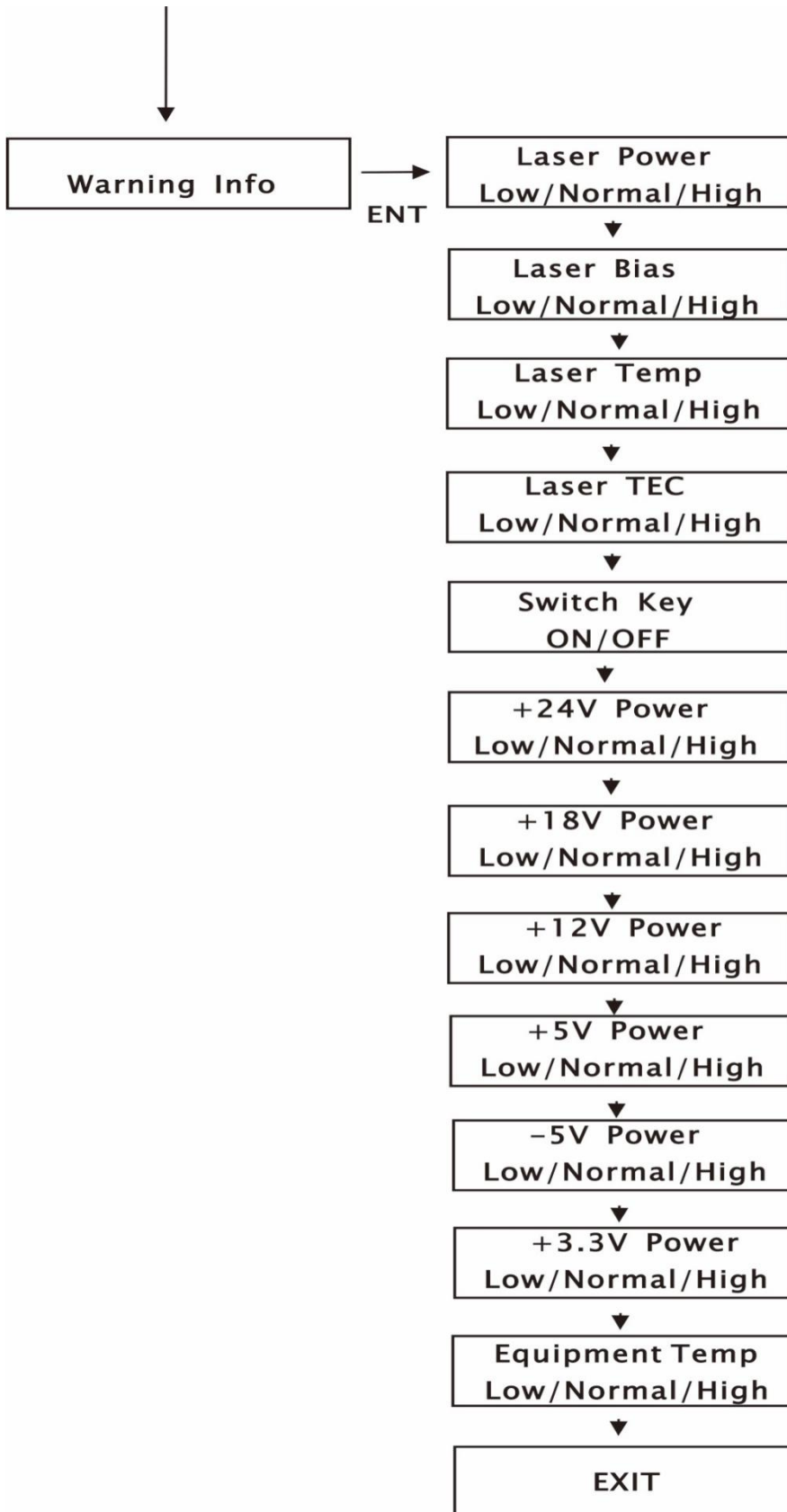



## 4. Precautions

4.1 The laser is core device of the optical transmitter; it is an electrostatic sensitive device. When storing the transmitter, pay attention to static protection. Can not be and corrosive items put together, storage temperature between -20 °C to +50 °C.

4.2 Do not use eyes on the fiber output, to prevent laser stabbing eyes.

4.3 Do not block the machine's cooling holes and keep them well ventilated.

4.4 The input RF power too large to overload will damage the laser.

## 5. Product warranty

5.1 warranty period one year start from the date of receipt of the device, one-year free repair.

5.2 During the warranty period, the user shall not disassemble the machine and shall not repair or change any part of the equipment on its own. Otherwise, the Company shall not be responsible for the consequences.

5.3 During the warranty period, due to the user in the use, storage failures, improper or accidents caused by the assembly are not covered by the warranty.

5.4 If the product does not meet the quality requirements, please send the product back to the company, the company will be dealt with under the terms of the warranty.

5.5 For more than the warranty period of my company to provide life-long repair, but the user needs to pay material costs.

## 6. Frequently asked questions

### ● Panel display normal, optical transmitter output optical power is not enough

Possible reasons:

1. optical power meter deviation.
2. test pigtail loss is too large.
3. connector dirty.

Troubleshooting:

1. clean optical power meter connector and pigtail surface with anhydrous industrial alcohol.
2. replace the test pigtail and clean the surface with anhydrous industrial alcohol.