

# Technical Specification

FTTx GPON CATV EDFA WDM



EDFA WDM PON 16 PORTS



# CONTENT

1.0 Product Description.....	1
2.0 Product Feature.....	2
3.0 Main Application.....	2
4.0 Technical Inex.....	3
5.0 Optic/Electrical Schema.....	4

## 1.0 Product description

JP1623EAP (2RU) series is a low noise, high performance, FTTP high power, multi-ports optical amplifier with gain spectrum band within 1540~1565nm. Each output port for optical amplifier has built-in well-performed CWDM. Every external up-link optical port of optical amplifier can connect with OLT PON port very conveniently. Each 1550nm (CATV)'s output optical port multiplex 1310/1490n's data stream, in order to reduce the quantity of the component and improve the index and reliability of the system.

JP1623EAP (2RU) optical amplifier can be compatible with any FTTx PON Technology. It offers a flexible and low-cost solution for three-network integration and Fiber to the Home.

JP1623EAP (2RU) LCD at the front panel offers the work index of all equipment and warning alarms. The laser will switch off automatically if optical power is missing, which offers security protection for the laser. All the optical port of optical amplifier can be installed in the front panel or back panel.

JP1623EAP (2RU) with carrier-class reliability and network security management, high quality, high reliability and excellent cost performance and is ideal for system integrators and system operator.

## 2.0 Product feature

- 1540~1565nm operating bandwidth for optical amplifier
- Each output optical port is with built-in high performance CWDM, single fiber three wavelengths, which can save optical fiber resources largely.
- Output adjustable by buttons in the front panel or web SNMP, the range is down 4dBm
- Can compatible with any FTTx PON technology: EPON/GEAPON, GPON, BPON, DPON
- Multi- ports output, can built in 1310/1490/1550WDM
- Low noise figure ( Typ  $\leq 4.5\text{dB}$ , Max  $\leq 5.0\text{dB}$  )
- Standard RJ 45 port for remote control, we can provide output contract and web manager for choice, and also plug-in SNMP hardware can be reserved for update.
- With laser key to turn on/off the laser
- Led displays the working condition of the machine
- Dual power hot plug power supply for choice, 90V~250V AC or -48V DC

### 3.0 Main application

- FTTx PON

- RFoG

### 4.0 Technique index

Performance			Index			Supplement
			Min.	Typ.	Max.	
Optical feature	CATV operation wavelength	(nm)	1540		1565	CATV
	OLT pass wavelength	(nm)		1310/1490		
	CATV pass wavelength loss	(dB)			0.8	1550nm
	OLT pass wavelength loss	(dB)			0.8	1310/1490nm
	CATV input power (Pi)	(dBm)	-10		+10	
	Number of output ports	(pcs)			16	16 PORTS
	Each port output power	(dBm)	0		13 ~23dbm	23dbm
	Difference of each output power	(dB)	-0.5		+0.5	
	Output optical power monitoring	(dB)		-20		
	Output power adjustable range	(dBm)	-3		0	
	Noise figure	(dB)		4.5	5.0	
				5.0	6.0	
	Polarization dependence loss	(dB)			0.3	
	Polarization dependence gain	(dB)			0.4	
Polarization mode dispersion	(ps)			0.3		

### 5.0 Optic/electrical schema

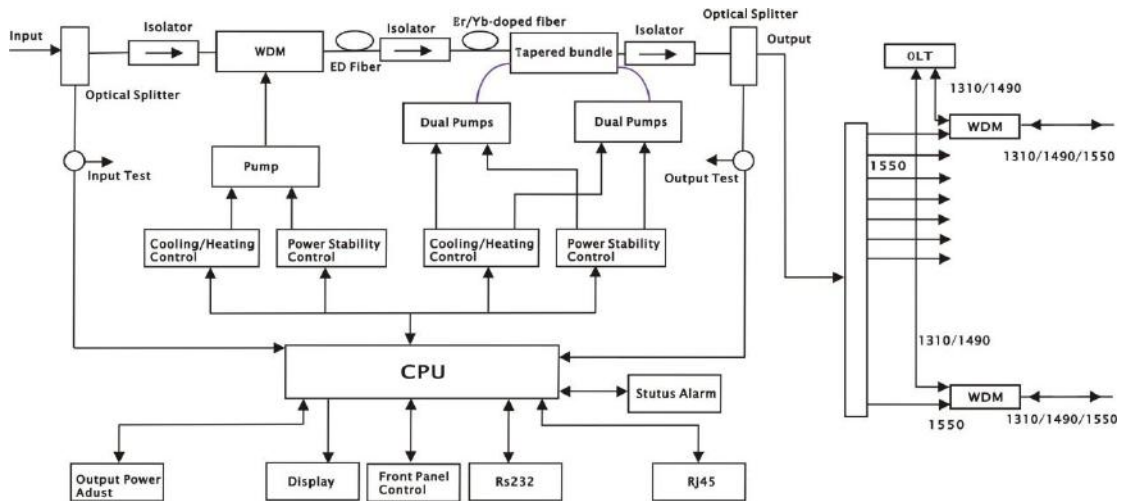

### 5.1 Front Panel

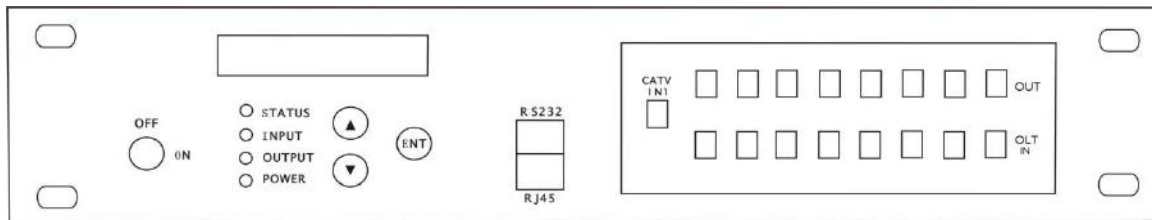

### Rear Panel

